

LITTERMAID[®]

AUTOMATIC Self-Cleaning Litter Box



Customer Care Line:

**USA/Canada
1-800-526-0650,
Option 1**

MODEL

- LM580**
- LM680C**
- LM980**
- LM-86579**

**For online customer service
and to order accessories/parts,
go to www.littermaid.com**

*Product may vary slightly from item pictured

PLEASE READ AND SAVE THIS USE AND CARE BOOK.

IMPORTANT SAFEGUARDS

Caution: Clumping litter is not intended for use with kittens under six months. If your kitten is under six months, always use litter formulated for kittens and leave your LitterMaid® litter box OFF until the kitten is the appropriate age.

- Please read all directions in this manual carefully prior to operating this product.
- Not intended for use by handicapped, incapacitated or older cats that may experience difficulty in entering or leaving the litter box.
- Pregnant women and immune-deficient people should avoid contact with cat waste at all times.
- **Caution: This is not a toy!** Never allow small children to play in or around this device.
- Your LitterMaid® Self-Cleaning Litter Box is a precision-operated appliance. Should the rake become jammed during cleaning, the unit contains a mechanism that will automatically stop, reverse and restart the cleaning operation (see TROUBLESHOOTING for more information).
- For cat use only and intended solely for the safe elimination of cat waste. Do not attempt to use this product for any other purpose.

SAVE THESE INSTRUCTIONS.



WELCOME TO THE *LITTERMAID* FAMILY!

Thank you for purchasing a LitterMaid® Self-Cleaning Litter Box! This Use & Care book will provide useful information on operating and maintaining your litter box, finding accessories, and troubleshooting for common issues.

In addition to this Use & Care book, our website also provides expanded information on a number of topics. As you're reading this book, you will see this  icon with an article title when the website provides additional information on that topic. Simply visit our website at www.littermaid.com and look for the title provided.

If you have any additional questions or concerns and cannot find the information you need either here or on our site, please call our customer care line at 1-800-526-0650, Option 1



TABLE OF CONTENTS

Section	Page
Getting to Know Your LitterMaid® Litter Box:	
• Litter Box Parts	5
• Mode Indicator Light	6
• Accessories	7
• Additional Accessories for Purchase	7
Selecting Litter	8
Acclimating Your Cat	8
How to Use	9
• Getting Started	9
• Preparing the Waste Receptacle	9
• Filling the Litter Tray	10
• Attaching Paw Cleaning Ramp	10
• Daily Use	10
Care & Cleaning	11
• Removing the Waste Receptacle	11
• Weekly Cleaning	12
• Paw Cleaning Ramp	12
• Motion Sensors & Top Housing	12
• Thorough Cleaning	12
• Rake Removal & Cleaning	12
• Litter Tray Cleaning	13
• Replacing Batteries	14
Troubleshooting	15,16



GETTING TO KNOW YOUR LITTERMAID® LITTER BOX

Product may vary slightly from what is illustrated.

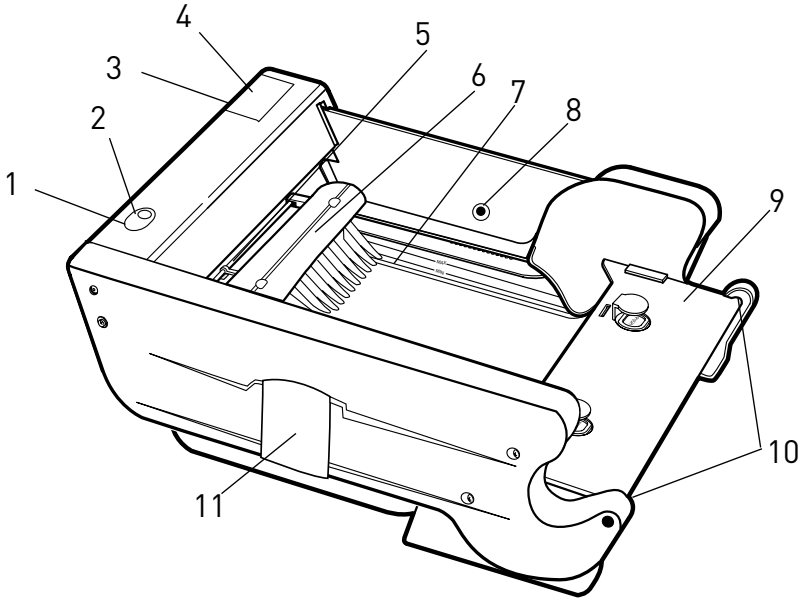

LITTER BOX PARTS

- 1. LED Indicator Light**
Indicates the current mode of litter box (see MODE INDICATOR LIGHT for details).
- 2. On/Off Button**
Turns the litter box on and off. You can also use this switch to activate the cleaning cycle mode.
- 3. AC Adapter Outlet (not shown)**
Plug in for regular power and daily usage.
- † **4. Battery Compartment Cover**
Takes 8, AA batteries. Use only for backup power during outages!
- 5. Safety Bar**
During use, the safety bar behind the rake will stop and reverse the raking action in case your cat jumps behind the rake during the cleaning cycle.
- † **6. Removable Rake**
Removes for easy cleaning.
- † **7. Litter Tray**
Fill only with premium hard clumping litter to ensure proper operation.
- 8. Motion Sensors (both sides)**
Activate the cleaning cycle.
- † **9. Waste Receptacle Compartment Cover**
Cover
Place the waste receptacle underneath and attach the receptacle lid to the compartment cover for automatic cleaning.
- 10. Paw Cleaning Ramp Attachment Posts (both sides)**
Use to attach the paw cleaning ramp accessory.
- 11. Litter Tray Latches (both sides)**
Unlock the litter tray cover for cleaning.

Note: † indicates consumer replaceable/removable parts





MODE INDICATOR LIGHT

Note: Your LitterMaid® system has an LED light on the back left corner of the top housing. The light will either be constant or blink, based on the current mode or cycle of the box.

LED Light	Mode
No light	Litter box is off.
Constant light	Litter box is on and in STANDBY mode.
Intermittent blinking (blinks 1 time every 2 seconds)	Litter box has activated CLEANING mode.
Slow blinking (blinks 1 time every second)	Litter box is in LOW POWER mode – indicates low battery power; replace the batteries (See TROUBLESHOOTING for details.)
Fast blinking (blinks 2 times every second)	Litter box has encountered a potential blockage and is in FAULT mode. The rake will automatically cycle 5 times to attempt to clear the blockage; if unsuccessful, the LED light will blink and the rake will return to the home position. (See TROUBLESHOOTING for details.)

ADDITIONAL ACCESSORIES

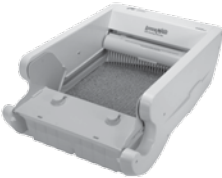
Included with your LitterMaid Automatic litter box model.

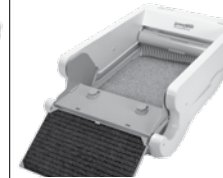
LM580	LM680C	LM980	LM-86579
			
<ul style="list-style-type: none"> • scoop and rake cleaner • 4 waste receptacles • 4 carbon filters • AC adapter 	<ul style="list-style-type: none"> • paw cleaning ramp • scoop and rake cleaner • 8 waste receptacles • 8 carbon filters • AC adapter 	<ul style="list-style-type: none"> • paw cleaning ramp • scoop and rake cleaner • 4 waste receptacles • 4 carbon filters • AC adapter 	<ul style="list-style-type: none"> • paw cleaning ramp • paw cleaning mat • scoop and rake cleaner • 8 waste receptacles • 8 carbon filters • AC adapter

ACCESSORIES

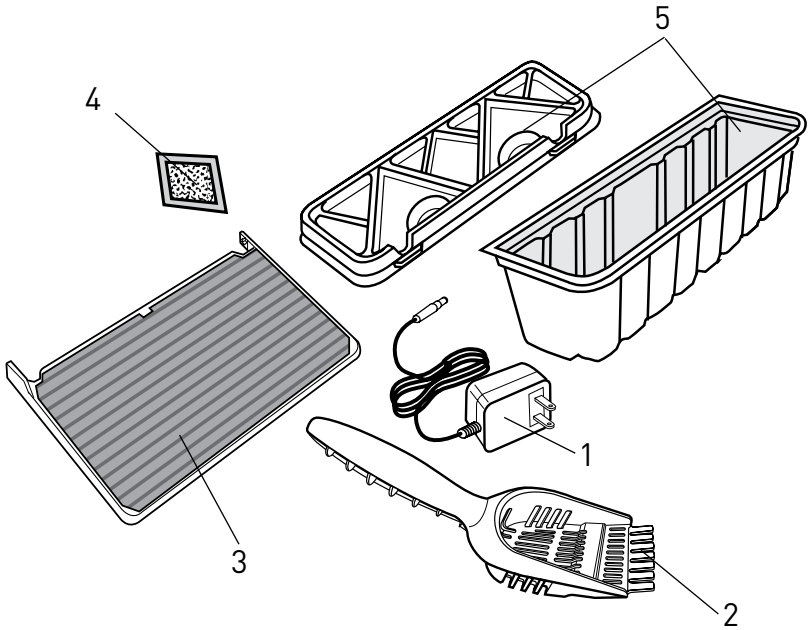

† 1. **AC Adapter**

Plug into the AC adapter outlet for regular power.

† 2. **Scoop & Rake Cleaner**

Use to clean the automatic rake, assist in measuring the litter level and for daily spot maintenance.

† 3. **Paw Cleaning Ramp**

Provides easy entrance and exit to the litter box for your cat as it cleans loose litter from paws. Included with LM680C and LM980 Models.

† 4. **Carbon Filter**

Helps reduce odors around the receptacle.

† 5. **Waste Receptacle & Receptacle Lid**

Heavy-gauge plastic contains waste with a sealable lid to help contain odors.

Note: † indicates consumer replaceable/removable parts

ADDITIONAL ACCESSORIES FOR PURCHASE

🐾 See Products/Accessories on littermaid.com

Purchase additional accessories for your LitterMaid system, like a Litter Box Carpet or Cat Privacy Tent directly from our website. A section of spare parts is also available for maintaining your LitterMaid system.

SELECTING LITTER

Your LitterMaid® system is designed to work with any premium hard clumping cat litter, so you can choose the litter that best suits your cat. We recommend the following:

- LitterMaid® Premium Natural Clumping Cat Litter
- Nature's Miracle™ Intense Defense Odor Control Clumping Litter
- Arm & Hammer® Super Scoop® The Baking Soda Clumping Litter*
- Fresh Step® Scoopable Premium Cat Litter**
- Ever Clean® Premium Clumping Litter**

Tip: For optimal performance, use with LitterMaid Premium Natural Clumping Cat Litter.

Important: Do not use non-clumping litter, crystal or pearl-like litters.

 See Litter Selection on littermaid.com

ACCLIMATING YOUR CAT

Some cats are finicky when it comes to their litter box area. In some cases, your cat may need to get used to its LitterMaid® Litter Box, which means you will need to acclimate your cat before removing your old box.

 See Acclimating Your Cat on littermaid.com

1. Place your LitterMaid® Litter Box next to your old litter box. Set it to run automatically by turning the on/off button on.
2. Do not clean previous litter box. (Since cats prefer to use a clean box and the LitterMaid® Litter Box will always be clean, they will transition to the new box on their own.)
3. If your cat seems timid around the LitterMaid Litter Box, turn it off so it will not run automatically for 2 to 3 days.
4. Each day, manually activate the box 2 to 3 times a day to allow cat to get used to it before setting it to clean automatically.
5. As soon as your cat is acclimated, set your LitterMaid® Litter Box to clean automatically.
6. Remove previous litter box.

* ARM & HAMMER® and Super Scoop® are registered trademarks of Church & Dwight Co., Inc.

** EVER CLEAN® and Fresh Step® are registered trademarks of The Clorox Pet Products Company

The Clorox Pet Products Company and Church & Dwight Co., Inc. are not affiliated with nor does it endorse or otherwise sponsor the Littermaid brand litter boxes.



How to Use

GETTING STARTED

Note: No tools required for setup.

1. Unpack all parts and accessories listed in the LITTER BOX PARTS section of this Use & Care manual. If applicable, remove any stickers.

2. Find a location for your LitterMaid® Litter Box in a clean, dry place.

Note: For optimal performance, do not place your LitterMaid® Litter Box in moist environment or in direct sunlight.

3. Cut and remove restraints on each end of the rake. Remove packing material from rake.

Note: Battery compartment takes 8 "AA" cell batteries. (Batteries not included.) Battery back-up is optional.

Important: Do not mix old and new batteries. Do not mix alkaline and carbon-zinc (standard) batteries. Do not use rechargeable type (Ni-Cad, Ni-MH or Li-ion) batteries.

PREPARING THE WASTE RECEPTACLE

1. Open waste receptacle compartment cover.

2. Place disposable waste receptacle under the compartment cover.

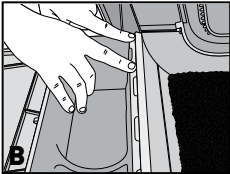

3. Make sure the front edge of the waste receptacle is under the five tabs on the front edge of the litter tray (B).

Note: There should be no gap between the litter tray and the waste receptacle.

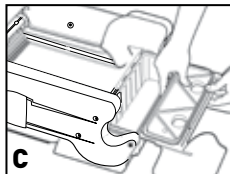

4. Attach the waste receptacle lid by inserting PUSH tabs into the round holes. To secure, press in and down at the positions indicated to slip the edges of the lid under the tabs on the waste receptacle compartment cover (both sides) (C).

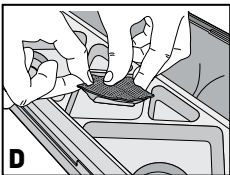

5. Remove carbon filter from plastic sleeve. Peel off paper strip to expose the adhesive. Place filter adhesive side down in diamond-shaped insert in the center of the waste receptacle lid (D).

6. Close waste receptacle compartment cover.



FILLING LITTER TRAY

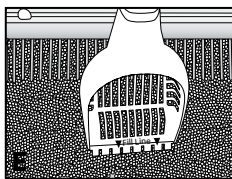

1. Fill your box so the litter level is between the **MIN** and **MAX** fill lines on either side of the litter box.
2. Use the scoop & rake cleaner to evenly distribute litter in the litter tray.

Tip: To measure litter at the center of the box, insert the scoop & rake cleaner, scoop down, into the center of the litter tray. The Fill Line on the scoop is even with the **MAX** fill line on the tray (**E**).

Important: Do not overfill unit or it will not operate properly.

ATTACHING PAW CLEANING RAMP (LM680C and LM980 MODELS)

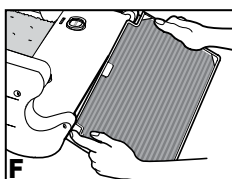

1. The paw cleaning ramp has two notches that snap onto the paw cleaning ramp attachment posts on the top housing, directly in front of the waste receptacle compartment cover.
2. Position the paw cleaning ramp with the carpet side facing up.
3. Place the notches over the paw cleaning ramp attachment posts on either side of the unit (**F**).
4. Tug slightly on ramp to ensure that it is firmly in place.

DAILY USE

1. Remove AC adapter from packaging and plug into the AC adapter outlet at the back of the top housing. Plug cord into a standard electrical outlet.
2. Turn the on/off button to **ON**; the mode indicator light will turn on.
Note: The rake will automatically run through a cleaning cycle to smooth out litter.
3. When your cat enters and leaves the litter box, the motion sensors will activate the **CLEANING** cycle. (Sensors must be blocked for at least 10 seconds to activate **CLEANING** cycle.)
Important: Unit will not start **CLEANING** cycle while cat is in the box.
4. After 20 minutes, the cleaning cycle will start and the automatic rake will move forward and back to scoop waste clumps into the waste receptacle.
Note: If the cat reenters and leaves the litter box before the initial 20 minutes have past, the timer will automatically reset and delay the rake action for an additional 20 minutes.



Note: Rake will stop and reverse direction if the safety bar touches any object behind the rake as it cycles.

Important: If the rake encounters a blockage, it will attempt to complete its cleaning cycle 5 times. If unsuccessful the rake will return to the home position and the LED light will blink quickly to indicate **FAULT** mode (see **TROUBLESHOOTING** for more details).

5. If small litter particles remain in the litter tray after the rake has completed a cycle, you can use the scoop & rake cleaner to move these particles to the waste receptacle.
6. If clumps of litter become stuck to the rake, use the teeth on the scoop & rake cleaner to clean between the teeth on the rake.
7. The disposable waste receptacle will keep odors and waste trapped until you are ready to replace the receptacle. Once the receptacle is full, remove and replace as instructed in **REMOVING THE WASTE RECEPTACLE**.

Care and Cleaning

Note: Your LitterMaid® Litter Box is designed to minimize daily maintenance, simply replace the waste receptacle and follow the instructions for weekly cleaning. More thorough cleaning is recommended once per month.

REMOVING THE WASTE RECEPTACLE

Caution: We recommend avoiding contact with waste material. Wear rubber or latex gloves when handling used waste receptacle, particularly if you are pregnant or have an immunodeficiency.

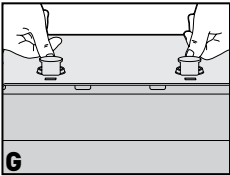

1. Press on the **PUSH** tabs on the waste receptacle lid to detach from the waste receptacle compartment cover (**G**).

2. Lift compartment cover; waste receptacle lid should already be detached and closed on the waste receptacle.

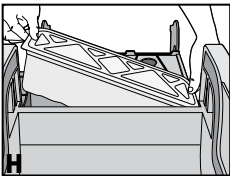

3. Press in on the four corners of waste receptacle lid to make sure it is secure.

4. Pull the disposable waste receptacle edge free from the tabs holding it in place (**H**).

5. Lift out and dispose.

6. Place a new receptacle, following the instructions in **PREPARING THE WASTE RECEPTACLE**.

WEEKLY CLEANING

Paw Cleaning Ramp

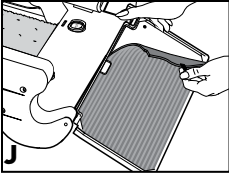

Note: The paw cleaning ramp is designed to remove litter from your cat's paws as it exits the litter box. As such, litter will get stuck to the carpet of the paw cleaning ramp as your cat uses the box daily.

1. Grasp the ramp on either side near the attachment points and lift up gently.
2. Grasp the carpet by the nylon pull tab on one side and lift up to remove (J).
3. Shake the mat to remove loose litter particles.
4. Tip over and empty the carpet holder to ensure no litter remains trapped under the carpet.
5. Replace the carpet by sliding the four corners of the carpet under the four holder points on the corners of the ramp. Make sure the tab at the back of the ramp is over the carpet to hold it in place.

Note: The carpet and ramp are both cut in on the back side near the attachment points. Always make sure you are putting the carpet into position correctly by matching the shape of the two pieces.

Motion Sensors & Top Housing

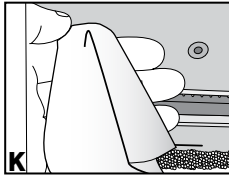

Note: The motion sensors on the inside walls of the litter box are what activate the **CLEANING** cycle. Keep sensors free of dust to ensure proper operation.

1. Use a soft, dry cloth or towel to gently wipe the sensors and remove any dust (K).
2. Then, use the cloth to wipe the exterior surfaces of the top housing to maintain its appearance.

THOROUGH CLEANING

Note: Clean thoroughly once a month to ensure optimal operation.

Important: We recommend wearing rubber or latex gloves when handling the soiled rake or litter tray.

Rake Removal & Cleaning

Note: The rake is removable for thorough cleaning. For quick cleaning, you can simply use the teeth on the scoop & rake cleaner to clean between the teeth of the rake.

1. To remove the rake for cleaning, press the on/off button and hold it for 5 seconds.

2. Release the button after 5 seconds and the MODE indicator light will start blinking.

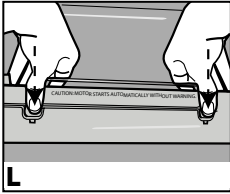

3. Rake will move forward and stop at the front of the litter box.

4. With both thumbs, press the two buttons on the safety bar to release rake (L).

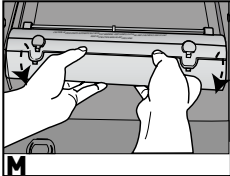

5. Pull rake out (M).
Important: Do not operate without the rake.

6. Wash the rake with a soft cloth using warm water and mild detergent. Dry thoroughly.

Note: Do not use scouring pads or harsh and abrasive chemicals.

7. Hold rake with both hands and align the two indentations on the rake with the two buttons on the safety bar.

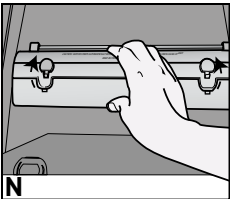

8. Push rake into the safety bar until it snaps into place both on top and on the bottom of the rake (N).

9. Press the on/off button and hold it for 5 seconds, the mode indicator light stops blinking and rake returns to home position.

Note: The rake will automatically return to the home position, 5 minutes after activating the cleaning cycle.

Litter Tray Cleaning

Note: It is not necessary to clean the tray each time you refill. Litter tray cleaning is recommended once a month.

1. To remove the litter tray for cleaning, check to make sure rake is in home position.

2. Turn the on/off button to off.

3. Unplug the unit and remove batteries to prevent accidental activation.

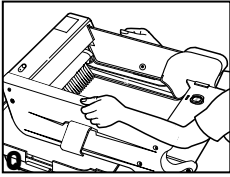
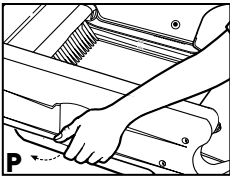

4. Lift the latches on both sides of unit (P). This will separate the litter tray from the top housing.
5. Lifting by the sides, move the top housing off and away from the litter tray (Q).
Important: Do not lift the top housing by the latches.
6. Dispose of any used litter in the litter tray. To ensure proper disposal of litter, follow manufacturer's instructions on litter package.
7. Wipe the litter tray with a damp cloth. If further cleaning is necessary, the litter tray can be fully immersed in water and washed with a mild detergent.
8. Wipe the top housing with a clean cloth, paying close attention to the rake track rails on either side of the top housing. If the rails have any litter caked on, use a soft, damp cloth to clean. Note: Keeping these tracks clean will ensure the rake functions properly.
Important: Do not soak or immerse top housing in water.
9. Dry litter tray thoroughly before reassembling.
Tip: Before reassembling, you can spray the inside of the litter tray surface with nonstick cooking spray or silicone spray, and wipe with a soft, dry cloth. This will help to prevent clumps from adhering to surface of the tray.
10. Place the litter tray on a flat surface. Carefully lower top housing onto the litter tray.
11. Lock the two latches by pressing lower part of each latch firmly against tabs on the litter tray until each latch clicks and locks into place.

REPLACING BATTERIES

Note: Battery power is not sufficient for the litter box to function regularly and should only be used during a power outage – not as the main power source.

1. Turn the on/off button off and unplug the unit.
2. Press back with your thumb to slide the battery compartment cover off the top housing.
3. Replace the batteries with 8, new AA batteries.
Important: Do not mix old and new batteries. Do not mix alkaline and carbon-zinc (standard) batteries. Do not use rechargeable type (Ni-Cad, Ni-MH or Li-ion) batteries.
4. Slide the battery compartment cover back into place, making sure the AC adapter outlet cover sticks out of the back of the unit.
5. Press firmly until the cover snaps into place – both at the top and back notches of the cover.

TROUBLESHOOTING

 See FAQ on littermaid.com

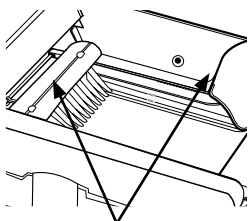
Problem	Possible Cause	Solution
<p>Mode indicator light blinks slowly (once per second).</p>	<p>Litter box is in LOW POWER mode – indicates low battery power and the rake function is disabled.</p>	<p>Check to make sure the litter box is plugged into a working outlet. Replace the batteries as instructed in CARE AND CLEANING (Note: battery power is meant to be used during an outage only; it does not provide enough power to run the unit continuously.)</p>
<p>Mode indicator light blinks quickly (twice per second); rake moves continuously.</p>	<p>Litter box is in FAULT mode. The rake has encountered a blockage either in front of or behind the rake. There may also be loose litter piled behind the rake that's preventing it from returning to the home position. As a result, the rake cannot complete its normal cycle. (Note: The rake will automatically cycle 5 times to attempt to clear the blockage; if unsuccessful, the LED light will blink and the rake will return to the home position.)</p>	<p>Turn the on/off button off and unplug the unit. Use the scoop & rake cleaner to clear any clumps or blockages that are preventing the rake from completing its cycle, as well as to level off the litter level, so the level is below the MAX line throughout the tray. Once blockages are removed, plug in and turn the on/off button on. If the unit still does not function correctly. Make sure the limit switches (located on the front right and rear middle of the unit) are not stuck. Both should be out.</p>  <p>Limit Switch</p>

Rake does not move after the cat exits the litter box and 20 minutes have passed.	Sensors may be dusty.	Wipe the sensors with a soft, dry cloth to remove any dust.
Rake does not completely clean litter box.	Low-quality litter may have been used.	Always use premium hard clumping cat litter. See SELECTING LITTER for more details.
Problem	Possible Cause	Solution
Waste clumps stuck to the litter tray.	Litter tray surface may need cleaning.	Clean litter tray as instructed in THOROUGH CLEANING .
Mode indicator light does not turn on when on/off button is turned on.	Litter box is not receiving power.	Check to be sure that the unit is plugged into a working outlet; during an outage check to make sure the batteries are working. (Note: battery power is meant to be used during an outage only; it does not provide enough power to run the unit continuously.)

Limited 1 Year Warranty

United Pet Group, Inc. (UPG) warrants [Automated Litter Box] against defects in material or workmanship for a 1 year period from the date of original purchase, subject to the conditions and exceptions stated below. Your sales receipt is your Proof-of-Date-of-Purchase. If the product exhibits such a defect, UPG will repair or replace it, at UPG's option, without cost for parts or labor. The product must be shipped postage paid to UPG. Proof-of-Date-of-Purchase is required. You are responsible for proper shipping.

This warranty does not cover damage caused by accident, misuse, abuse or failure to follow the instructions accompanying the Automatic Self-Cleaning Litter Boxes. All implied warranties, including any implied warranty of merchantability or fitness for any purpose are limited to time period. Fish and plant loss, personal injury, property loss or damage (direct, incidental, or consequential) resulting from the use of this product are not covered by this warranty.

Because some states/provinces do not allow the exclusion or limitation of incidental or consequential damages, or allow limitations on how long an implied warranty lasts, the above limitations or exclusion may not apply to you. This warranty gives you specific legal rights. You may also have other rights which vary from state/province to state/province.

